

Needle Valve - Sub-plate mounting, Model : MHNL



the right connection

Ref. No : H02758, Release Jan 2006 (Dimensions in mm)

Description

Needle valves model MHNL are rising spindle, seat type valves with taper needle construction.

The mounting interface conforms to Factory standard.

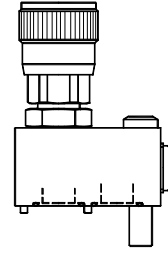

Section

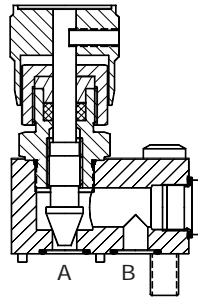

Hydraulic Symbol

Unit Dimensions

Valve

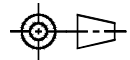
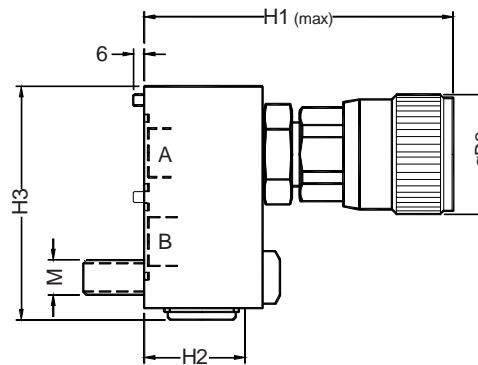
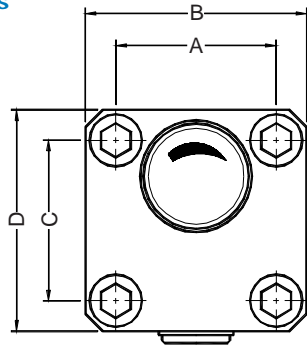

Model Code	A	B	C	D	H1	H2	H3	ØD2	Valve fixing screws (10.9)	
									M	Tightening Torque
MHNL11-2.0	47.8	65	60.5	78	116.0	33.0	79	37	M10x50L	16Nm
MHNL19-2.0	65.0	97	81.0	113	140.0	22.2	118	48	M16x50L	117Nm
MHNL28-2.0	92.0	127	92.0	127	156.5	58.0	131	68	M20x90L	238Nm

Unit Dimensions

- Construction Seat type.
- Mounting type Sub-plate mounting type.
- Interface Factory standard.
- Flow direction From port `A' to port `B'.
- Operating pressure 350 bar.
- Hydraulic medium Mineral oil.
- Viscosity range 10 cSt to 380 cSt.
- Fluid temperature range -20 °C to +70 °C
- Fluid cleanliness requirement As per ISO 19/16 or better.
- Mass
 - MHNL11-2.0 - 1.5 kg.
 - MHNL19-2.0 - 3.6 kg.
 - MHNL28-2.0 - 8.5 kg.
- Maximum flow handling capacity Refer graph.

Needle Valve - Sub-plate mounting, Model : MHNL



the right connection

Ref. No : H02758, Release Jan 2006 (Dimensions in mm)

Interface - Factory standard

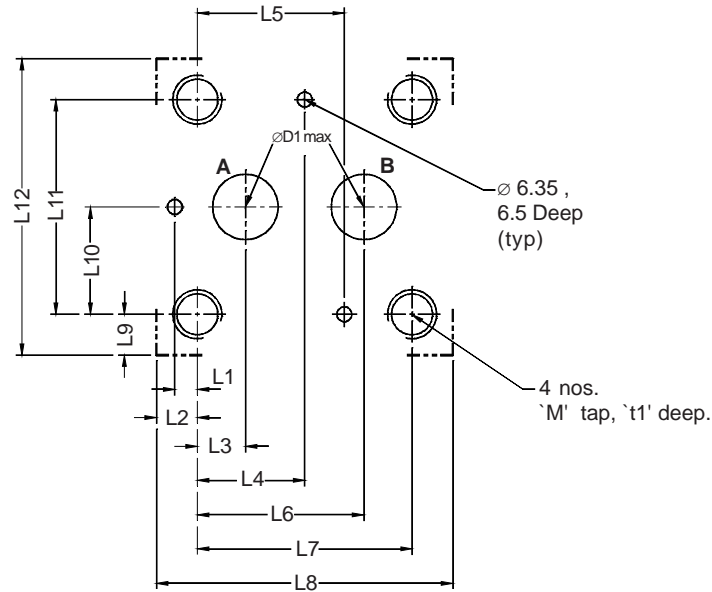

Model Code	$\varnothing D1$	L1	L2	L3	L4	L5	L6	L7	L8	L9	L10	L11	L12	M	t1
MHNL11-2.0	11.0	--	8.6	12.7	30.3	47.8	47.8	60.5	78	8.6	23.9	47.8	65	M10	15
MHNL19-2.0	19.0	8.70	16.0	22.2	40.5	--	68.3	81.0	113	16.0	32.5	65.0	97	M16	24
MHNL28-2.0	28.0	9.65	17.5	20.6	46.0	--	71.4	92.0	127	17.5	46.0	92.0	127	M20	30

Performance Curves

Oil used : ISO VG 68,
 Viscosity : 68 cSt @ 40 °C
 Test conducted at : 50 °C.

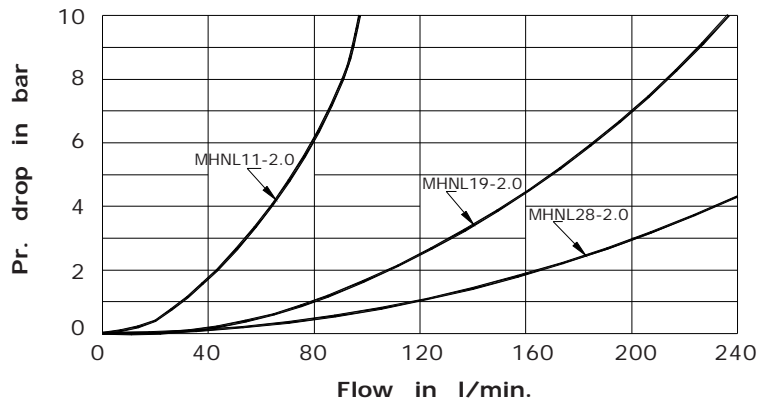

Ordering Code

